



hyperMILL[®]

2025

hyperMILL[®] 2025

WHAT'S NEW?

 **OPEN MIND**
THE CAM FORCE



What's new in *hyperMILL*® 2025?

hyperMILL® 2025 offers you even more performance and efficiency, both for CAD and CAM. With the new tessellation algorithm and the new, simplified element display for CAD models, as well as improved algorithms of our 3D strategies, you benefit from noticeably faster working and even more precise processing results.

A highlight of the new *hyperMILL*® release are three innovative strategies for deburring holes and part edges – for maximum flexibility and the highest quality. In addition, the new 5-axis automatic tool orientation mode ensures optimized machining and delivers efficient and reliable tool paths, even for the most complex components.

CONTENT

3-4

CAD

Set new layer to current

Improved linear sweep

Optimized performance for large component groups

Triple tangential fillet

New tessellation technology

Extended STEP interface

Display virtual electrodes

Optimized electrode process

5-11

CAM

Read back 2D measurement data

3D Optimized Roughing

3D Plane Machining

Hole Brushing NEW STRATEGY

5-axis Hole Deburring NEW STRATEGY

5-axis Deburring NEW STRATEGY

5-axis ISO Machining NEW STRATEGY

5-axis Profile Finishing NEW STRATEGY

5-axis Radial Machining

5-axis Halfpipe Machining

Turbine Blade Machining

Part transfer with DMG MORI NTX and NT

Fixture definition for turning

V-sketch for turning contours

12-15

TECHNOLOGY

Job calculation with virtual machine

JIG Grinding with *hyperMILL*® VIRTUAL Machining

Turret support for controls from FANUC and Mitsubishi

Solution selection: Closest C-axis angle

Linking with dynamic stock

Automatic stock chain

Optimal barrel cutter

Rest material boundary

***hyperMILL*® AUTOMATION Center Controller**

hyperMILL® ADDITIVE Manufacturing

hyperMILL® VIRTUAL Machining

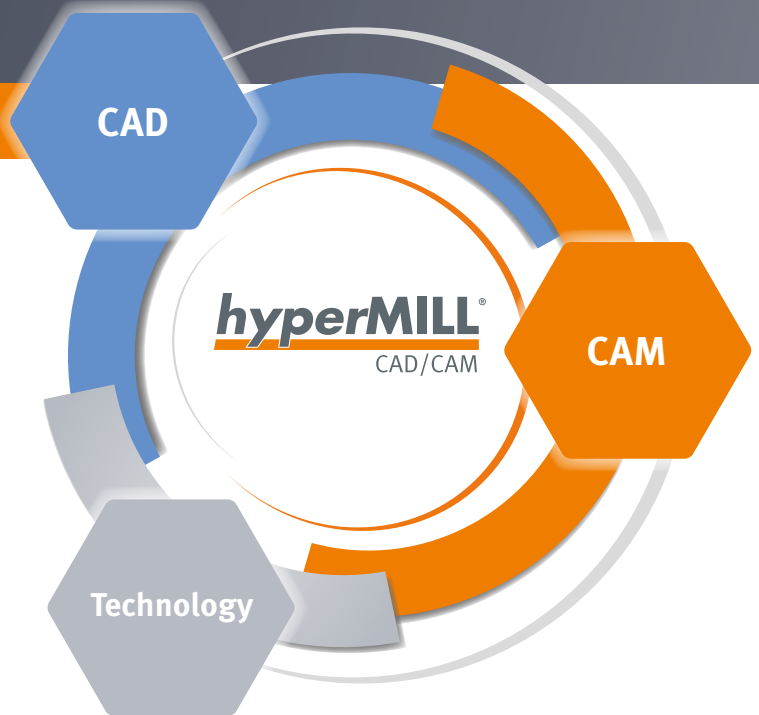

Review system compatibility: To ensure optimal performance and stability, we recommend regularly running our diagnostic program, Systemchecktool.exe.

Note: Windows® may reset the graphics driver or its settings when carrying out updates.

System requirements: Windows® 10/11 (64-Bit) | **CAD integrations:** Autodesk® Inventor®, SOLIDWORKS

Software languages: de, en, es, fr, it, nl, cs, pl, ru, se, sl, tr, pt-br, ja, ko, zh-cn, zh-tw

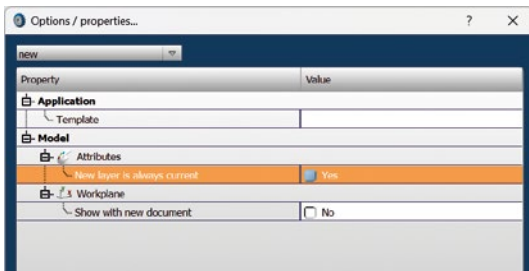

Set new layer to current

hyperMILL® now offers the option of automatically setting newly created layers active. This saves you time-consuming manual selection.

Benefit: Increased user-friendliness.

HIGHLIGHT

Improved linear sweep

hyperMILL® now allows you to easily extrude even highly complex sketches with a defined angle of inclination. Surfaces that intersect with themselves or others are automatically trimmed. This allows you to quickly and accurately create complex surfaces, such as those needed for molds or electrodes.

Benefit: No rework required for highly complex sketches.

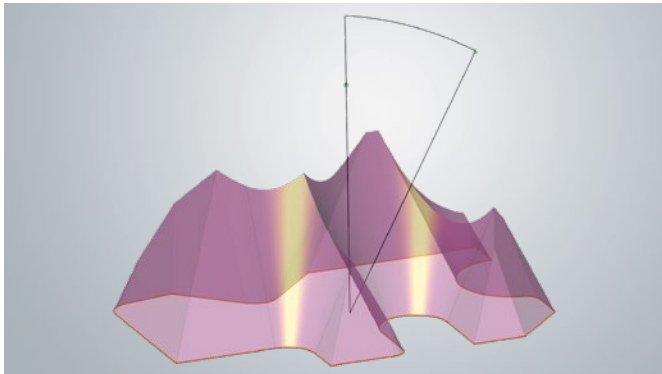

HIGHLIGHT

Optimized performance for large component groups

Thanks to our new “Switch visibility on/off” function, you benefit from significantly improved performance when working with large assemblies. Even before loading a file, all layers can be set to non-selectable so that the model responds more smoothly from the start. You can activate individual layers as required to carry out specific edits.

Benefit: Smooth workflows for complex models and large projects.

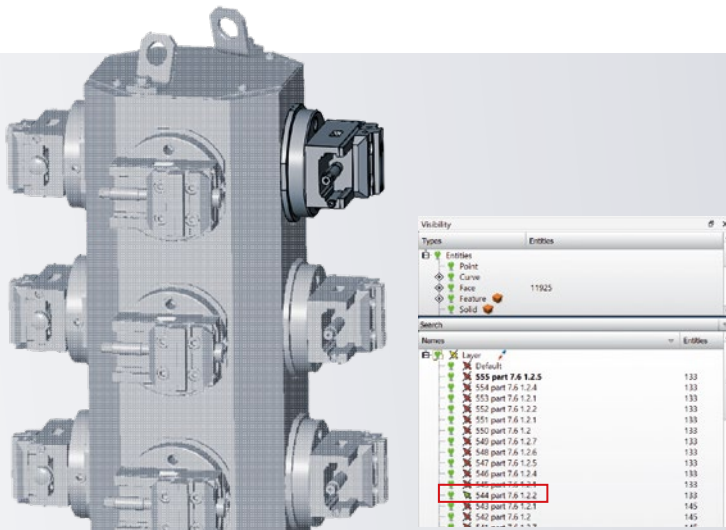

HIGHLIGHT

Triple tangential fillet

With *hyperMILL*® you can now create seamless fillets between three adjacent surfaces while maintaining full continuity. This function saves you valuable time when modeling complex geometries, such as turbine blades, while ensuring the highest precision and quality of your models.

Benefit: Fast and precise creation of triple tangential fillets.

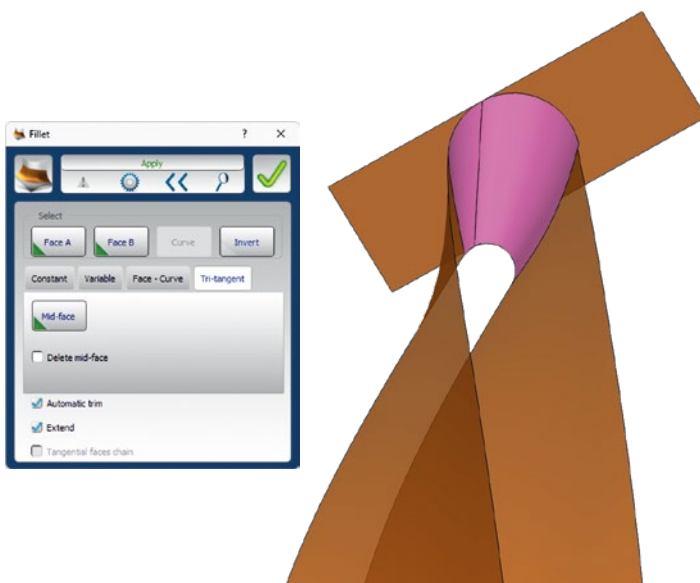

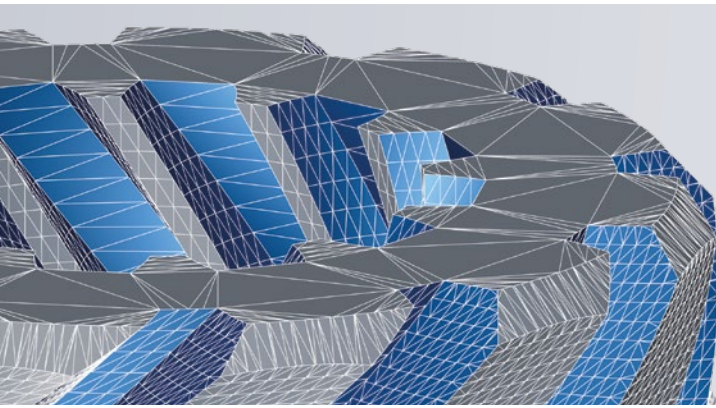
HIGHLIGHT**New tessellation technology**

We have developed an entirely new tessellation technology that significantly improves performance when loading as well as during daily work. Curves, surfaces, their edges, and solids use the same setting option and can be adjusted via a single parameter.

Benefit: Significantly improved performance and simplified operation.

Extended STEP interface

With our extended STEP interfaces, you benefit from even more comprehensive data transfer. Names for curves and surfaces are now fully retained, providing you with more information for your processes. In addition, colors and tags from surfaces are transferred to rotational shape contours, ensuring that the 2D contours are ready for further processing along with all relevant Product Manufacturing Information (PMI). This ensures optimum process integration and saves valuable time in production.

Benefit: Improved process integration and increased efficiency in manufacturing.

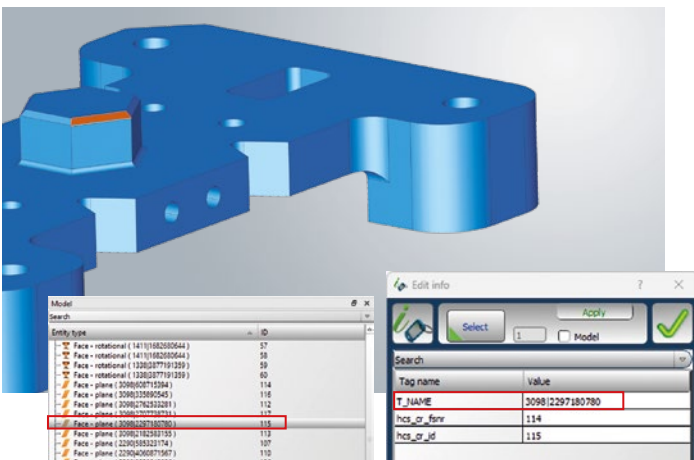
**Display virtual electrodes**

In *hyperMILL*® Electrode, all created virtual electrodes can now be shown and hidden. This allows you to easily determine which electrodes have already been defined. Furthermore, with a large number of electrodes, performance is increased when unused electrodes are hidden.

Benefit: Simplified management of virtual electrodes.

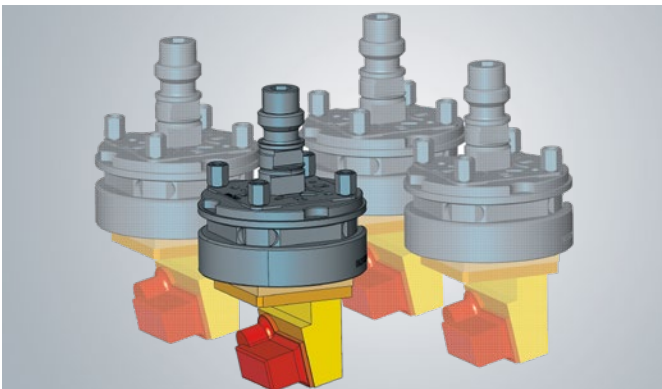
**Optimized electrode process**

Benefit from new functions for even more efficient electrode production. In addition to the option of using a variable as a name, as well as an optimized mirroring command, you can now simulate an undersize for the electrode. This specifically limits potential collisions on the erosion path — ensuring safe processing.

Benefit: Improved planning and execution of electrode processing through collision-checked simulation.

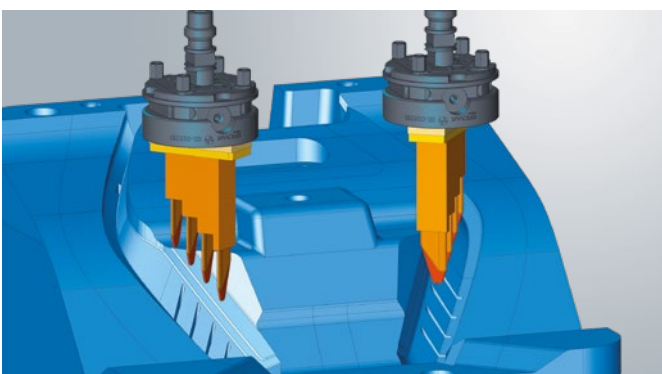

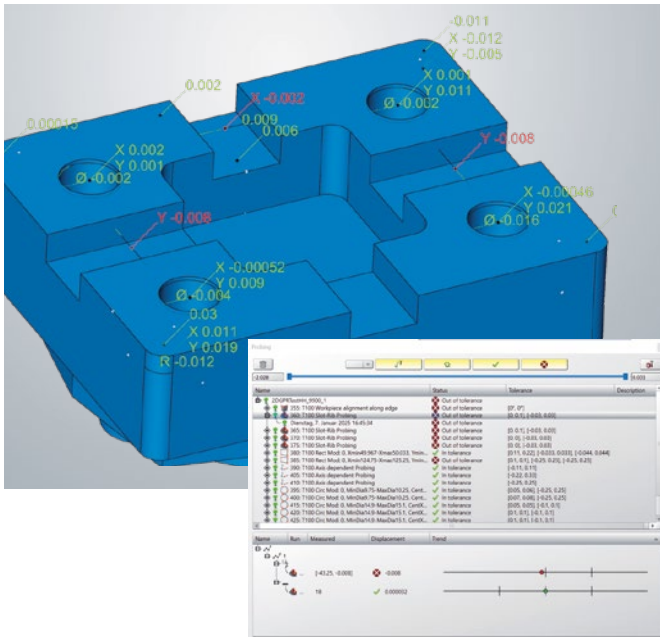

Read back 2D measurement data

Through our own exchange format, 2D measurement results, such as axis-dependent, circular, rectangular, groove or rib measurements, can now be read back from the control into *hyperMILL*®.* Which measurement results fall within or outside of tolerance is displayed at a glance in *hyperMILL*®. This way, you can easily monitor the manufacturing trend, for example for diameters or positions.

In addition, reading back 2D measurement results can be used in conjunction with *hyperMILL*® BEST FIT to quickly check center tolerances or positions. The BEST FIT process based on 2D data can be used to accelerate the interpretation of the 3D probing results, comparing before and after BEST FIT.

Benefit: Graphical display of 2D measurement results for simplified quality control in *hyperMILL*®.

**hyperMILL*® VIRTUAL Machining post-processor required. Available controls on request.

HIGHLIGHT

3D Optimized Roughing

The pocket milling algorithm has been redeveloped for the roughing mode of the strategy in order to achieve greater efficiency during roughing and better machining control. A benefit of the new version is realized when machining with large lateral infeeds and remaining material. Additionally, you can define a contour radius and a path radius, allowing you to better control toolpath roundings. The contour radius is used for toolpaths along the model geometry, while the path radius is used for all other offset paths.

Benefit: Faster rough machining and improved behavior with large infeeds and rest material.

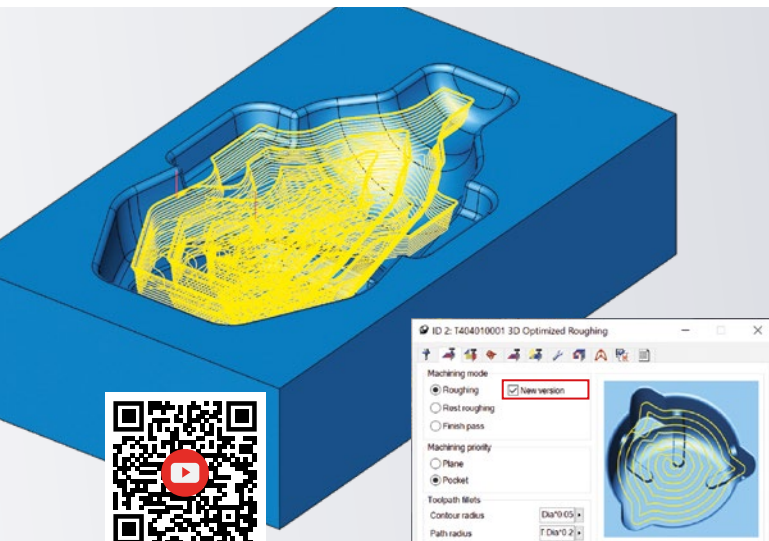

3D Plane Machining

The new “axis parallel mode” machining strategy opens up extended options for machining flat surfaces. It allows for processing surfaces along a definable direction. In standard and high feed mode, you have better control over the tool path rounding, as you can also define the contour radius and path radius separately from each other. The contour radius is used for the tool paths that run along the model geometry. The path radius is used for the other offset paths.

Benefit: Extended possibilities and improved control through new strategies and functions.

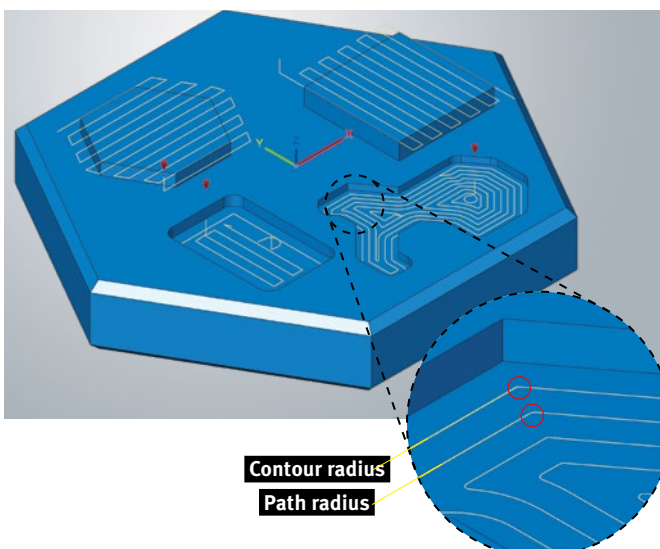

HIGHLIGHT

New strategies for precise deburring

Burr-free edges and holes are not only functionally important, but also an essential component of a high-quality end product. With *hyperMILL*® 2025 you have a comprehensive selection of deburring strategies available directly at the machine.

1 Hole Brushing

Use this new strategy to deburr or improve the surface quality of cross holes, threads, or other features with a special brushing tool. The machining process is divided into different phases, and for each phase, machining parameters such as spindle speed, feedrate, coolant, and dwell time can be defined. Under the “Parameters” tab, settings for the machining area, brushing direction, and the number of repetitions can also be made.

Benefit: Easy programming of a brushing tool and deburring of holes and other features.

2 5-axis Hole Deburring

This new strategy makes it very simple to deburr sharp edges on holes and intersecting holes. Thanks to our intelligent function, the CAM Plan, all holes are automatically recognized, and all sharp edges in the model are marked. You only need to select the desired edges, and the strategy automatically calculates all toolpaths. The strategy supports a 3-axis mode, which is already included in the *hyperMILL*® 3D package, and a 5-axis mode. In the 5-axis mode, machining is indexed where possible. If this is not feasible, it is carried out with 5-axis simultaneous movements.

Benefit: Fast, simple, and safe deburring of holes.

3 5-axis Deburring

This new *hyperMILL*® strategy provides you with a fast and effective solution to deburr all sharp edges of a part. You can choose between a 3-axis machining, which is already included in the *hyperMILL*® 3D package, and a 5-axis machining mode. Thanks to the 5-axis option, you can reach more component edges, and the necessary inclinations as well as collision avoidance are generated automatically. The edges are preferably machined with a fixed approach. If this is not possible, simultaneous machining is used. This strategy supports both lollipop and ballmill cutters.

Benefit: Fast and effective deburring of component edges.

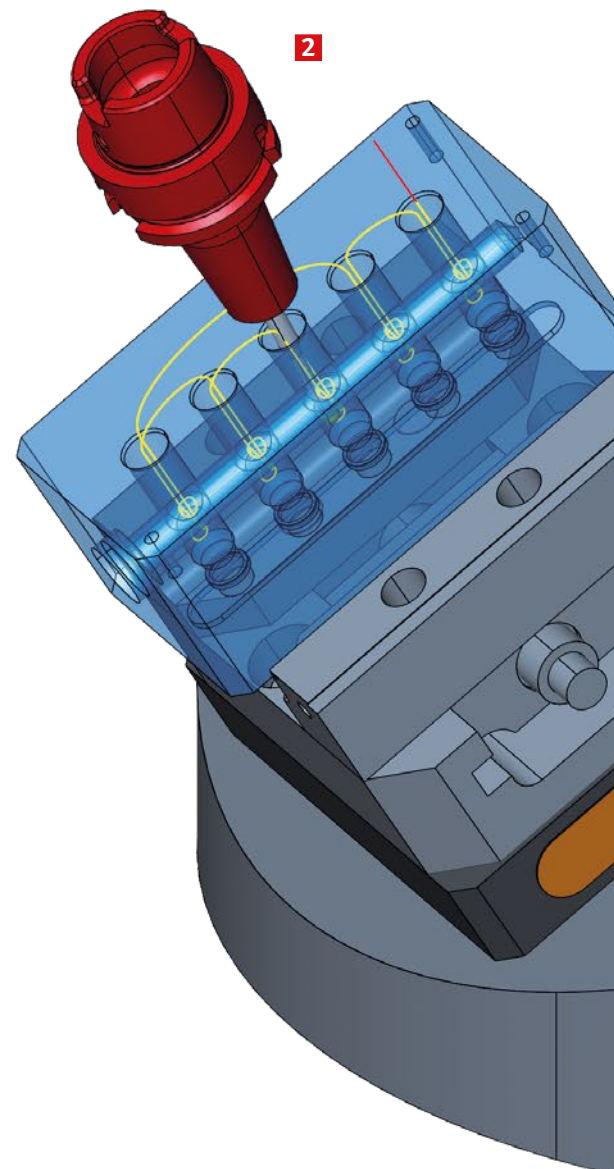

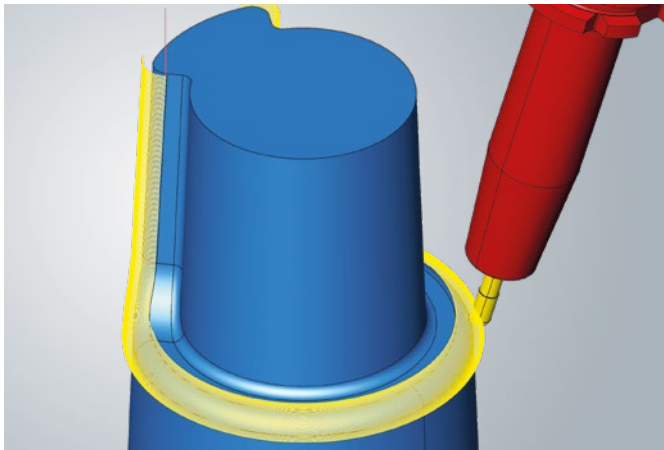
**HIGHLIGHT****5-axis ISO Machining**

Use our new 5-axis strategy* to machine individual or a few contiguous surfaces according to the course of the ISO lines (U and V). The functions that you are already familiar with from 3D ISO Machining can now also be used for 5-axis machining. In addition to feed adjustment for curvatures and 3D radius correction, the high-precision surface mode can be used with our True-Shape Technology.

Benefit: 5-axis machining of ISO surfaces with increased surface quality and programming support through intelligent algorithms.

*Licensing required.

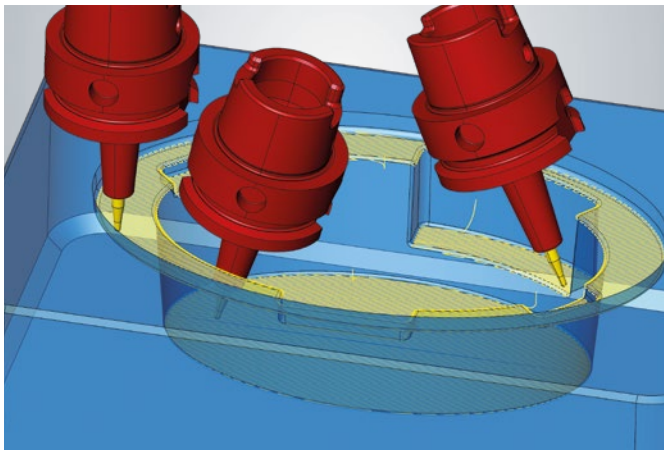
**HIGHLIGHT****5-axis Profile Finishing**

We have fundamentally revised this strategy and offer you a new, improved version of 5-axis Profile Finishing. Many familiar and innovative features from “3D Profile Finishing” are now also available for 5-axis machining. Additionally, the strategy offers a new algorithm for the automatic tool orientation strategy. Utilize familiar functions such as smooth overlapping, automatic milling surface extension, trimming to the milling area, adjustment of curvature feedrate, or 3D path compensation to make surface machining more efficient, easier, and faster. With the option “True-Shape Point Distribution”, you achieve an optimal point distribution for machining. This leads to a higher surface quality and consistent machine movements.

Benefit: Faster and simplified programming, higher surface quality, and programming support through intelligent algorithms.

**New 5-axis automatic tool orientation mode**

Thanks to the pre-analysis of the entire tool path, our new 5-axis algorithm calculates an optimal machining sequence of simultaneous and indexed tool movements. Indexed machining is the preferred and fastest machining sequence. Simultaneous machining is only carried out for toolpath segments that require simultaneous machining. Users benefit from a reduction in the number of inputs required for 5-axis machining and save time when programming complex machining operations.

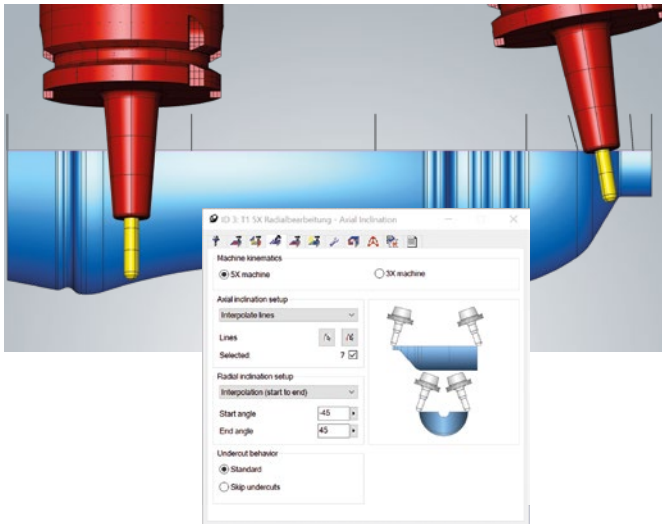

5-axis Radial Machining

Two innovations in this strategy provide improved handling of 5-axis machining parameters and higher surface quality thanks to our True-Shape Technology.

With the new option “Interpolate between lines”, you can manually determine the axial inclination of the tool. Simply define inclination lines along the center curve and the tool inclination is interpolated between the individual lines.

With the option “True-Shape Point Distribution”, you achieve an optimal point distribution for milling and thus ensure perfect surface quality and consistent machine movements.

Benefit: Individual control of the axial tool inclination and improved point distribution for optimal surface quality.

True-Shape Technology



With our True-Shape Technology, you benefit from optimal point distribution for surface machining. It generally ensures more homogeneous machine movements and is the basis for high-precision machining. In conjunction with the CAM Plan, the topology information of the part surfaces is created automatically. If you activate the high-precision surface mode with True-Shape Point Distribution, *hyperMILL*® now provides you with predefined tolerance specifications for pre-finishing, finishing, fine finishing and micro-finishing. *hyperMILL*® controls the optimum machining parameters for you.

5-axis Halfpipe Machining

For endless shaped grooves, a continuous spiral is now also available between the two boundaries. It starts downwards on the selected start side and continues upwards on the opposite side without interruption. Surface damage on the bottom (between the two sides), which can be caused by kinematic errors or tool wear, can be avoided with this machining strategy.

Additionally, you can now set a lead angle for geometries with two open ends and infinite geometries. This is helpful to prevent contact with the tool tip.

Benefit: Improved machining parameters.

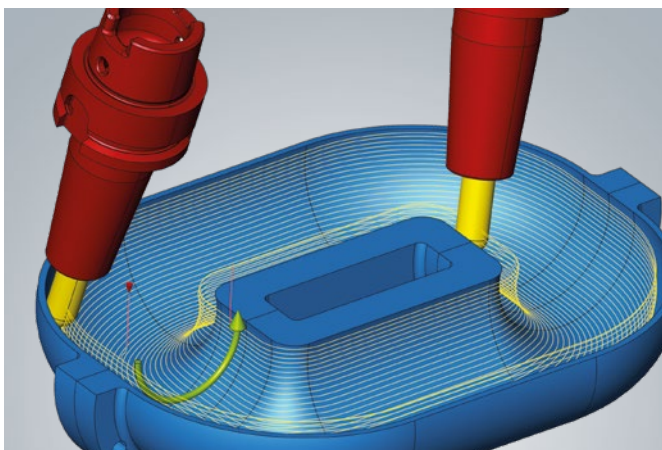

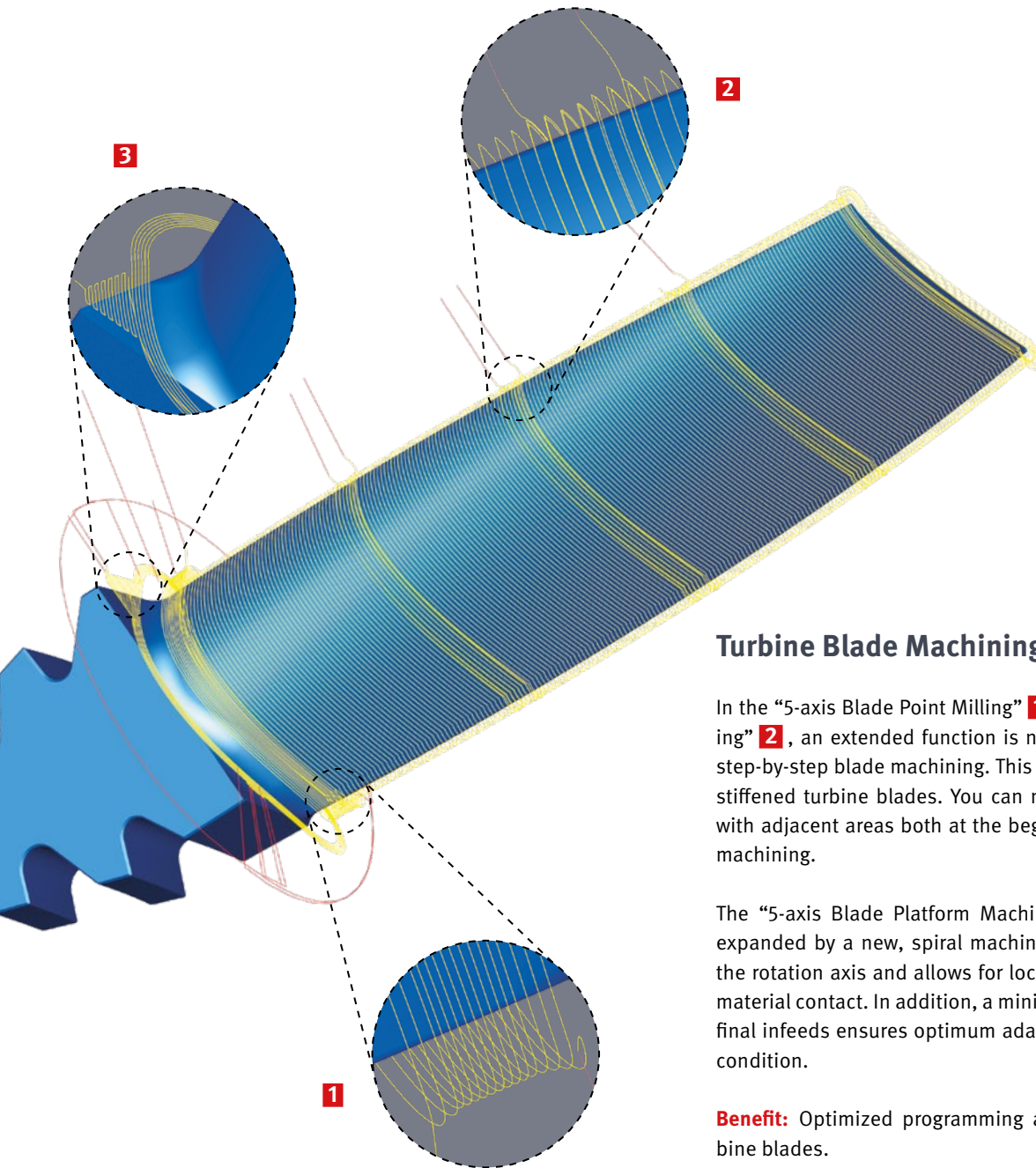

Turbine Blade Machining

In the “5-axis Blade Point Milling” **1** and “5-axis Blade Top Milling” **2**, an extended function is now available to optimize the step-by-step blade machining. This is often the case with long or stiffened turbine blades. You can now use smooth overlapping with adjacent areas both at the beginning and at the end of the machining.

The “5-axis Blade Platform Machining” **3** strategy has been expanded by a new, spiral machining that prevents reversal of the rotation axis and allows for locally higher feedrates without material contact. In addition, a minimal number of uninterrupted final infeeds ensures optimum adaptation to the pre-machining condition.

Benefit: Optimized programming and finish machining of turbine blades.

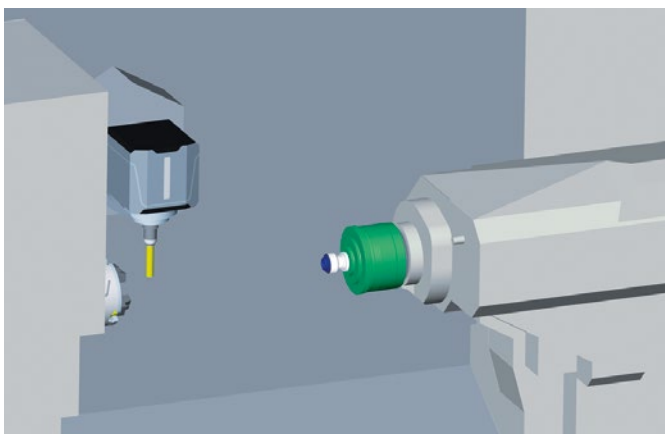

Part transfer with DMG MORI NTX and NT

For lathes of the NTX and NT series from DMG MORI with main and counter spindle as well as B-axis, you can now use the part transfer in combination with the SIMULATION Center*. Conveniently program machining operations with main and counter spindle in one job list and simulate the machining sequence in detail.

Benefit: Simplified and safe programming of the transfer job for these DMG MORI machines.

*An update of the postprocessor is necessary.

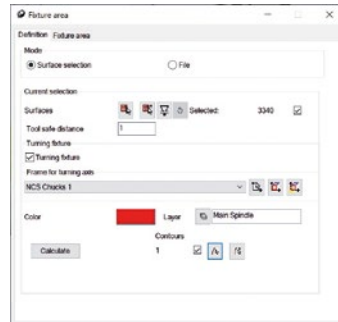
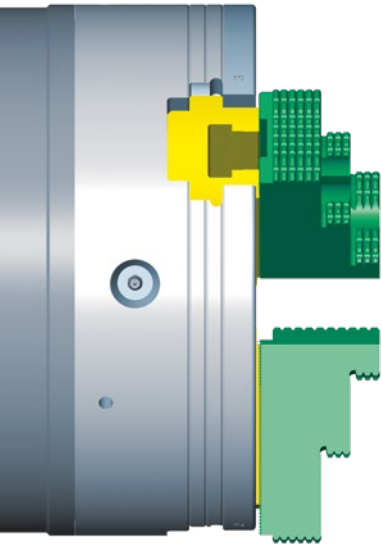

Fixture definition for turning

The improved definition of turning fixtures ensures that the calculation of the 2D fixture contour can now already take place during the fixture setup. When creating a 2D fixture, you can determine which layer the contour should be placed on. With the “Calculate” command, the 2D fixture contour is calculated and is available to you immediately in all turning jobs as 2D feedback. When changes are made to the fixture definition, the fixture contour must be recalculated.

Benefit: Improved loading time of 2D feedback in turning jobs.

HIGHLIGHT

V-sketch for turning contours

Create a special V-sketch for turning in an easy and automated way. Starting from a 3D model that is typically designed with nominal dimensions, the V-sketch with turning contour is generated almost fully automatically. A command is used to define horizontal dimensions and assign corresponding tolerance specifications. Based on these values, the turning contour can be moved to the center of the tolerance. Thanks to the new V-sketch for turning, you can also prepare your turning contour with undercuts, edge breaks and tolerances quickly and efficiently for programming.

Benefit: Fast and dimensionally accurate turning contour creation, based on a 3D model.

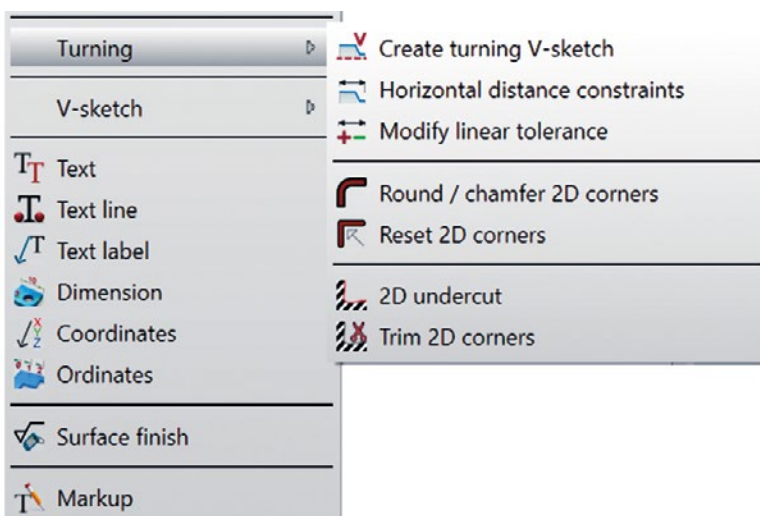
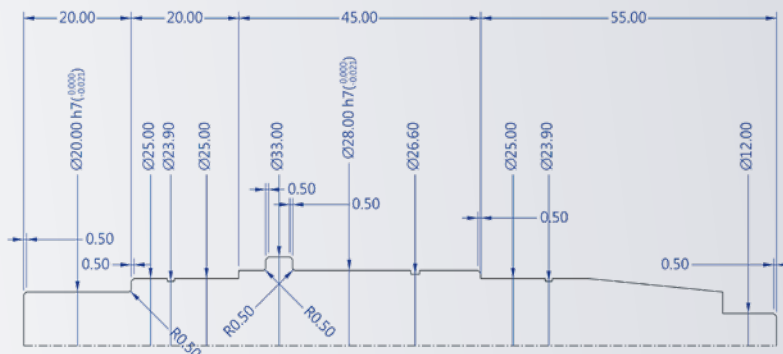

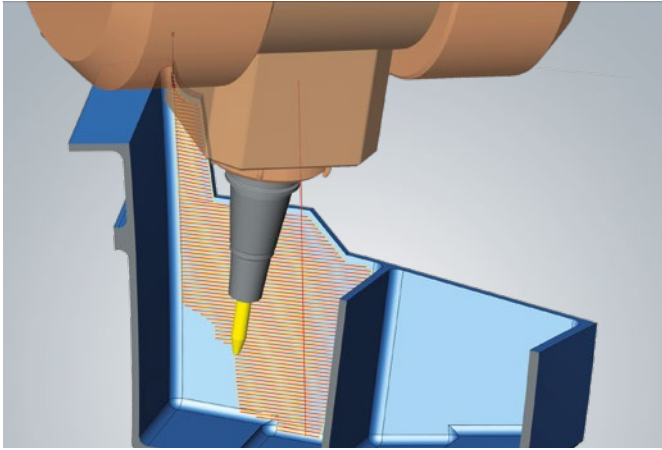
**HIGHLIGHT****Job calculation with virtual machine**

With the new option “Use VM for calculation”, *hyperMILL*® uses the machine model directly during tool path calculation. Collision control and avoidance take place considering the machine geometry and limits. The result: more precise and optimized tool paths, especially in tight spaces or when the machine head is working close to the part or machine limits. Residual material areas that arise due to collisions or machine limits can be re-worked as usual with other strategies and without visible transition thanks to the “Smooth overlap” option.

The usual flexibility remains : The option can be specifically used for individual machining jobs, and a machine change is still possible without recalculation.

Benefit: Calculation of collision avoidance using the machine model.

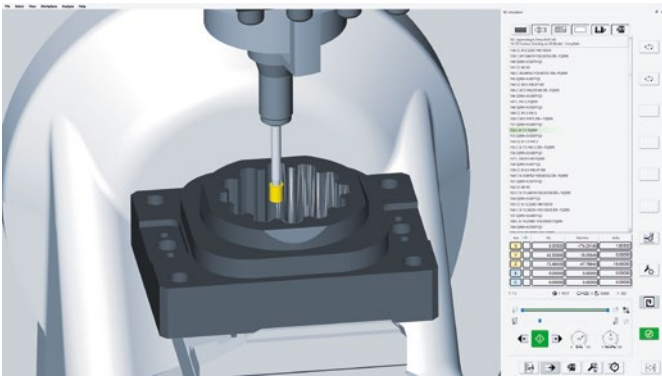
**JIG Grinding with *hyperMILL*® VIRTUAL Machining**

Our *hyperMILL*® VIRTUAL Machining technology now also supports jig grinding. Your machining with fast-stroke grinding movements is fully checked for possible collisions and simulated in detail. *hyperMILL*® VIRTUAL Machining utilizes functions from your machine control.

Benefit: NC simulation for jig grinding.

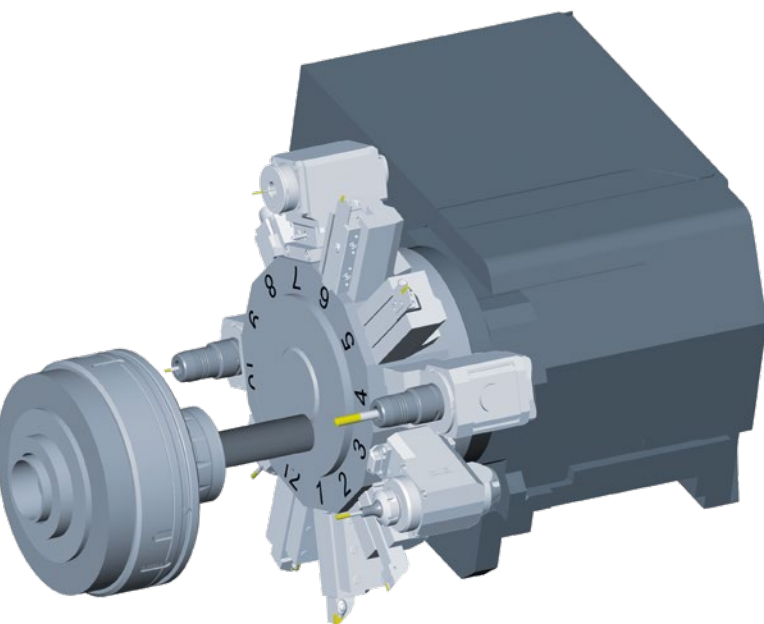
**Turret support for controls from FANUC and Mitsubishi**

Lathes with a turret and a main spindle are now supported by our *hyperMILL*® VIRTUAL Machining technology in conjunction with FANUC and Mitsubishi controls. This enables you to program these machine types easily and safely. Your machine and all tools are mapped in detail and used for NC code simulation. You can conveniently equip the turret with holders and tools in the virtual machine’s processing planner. With this release, we now extend turret technology for the controls of the following manufacturers:

- Siemens
- FANUC
- Mitsubishi

Benefit: Support for new machine controls.

HIGHLIGHTS

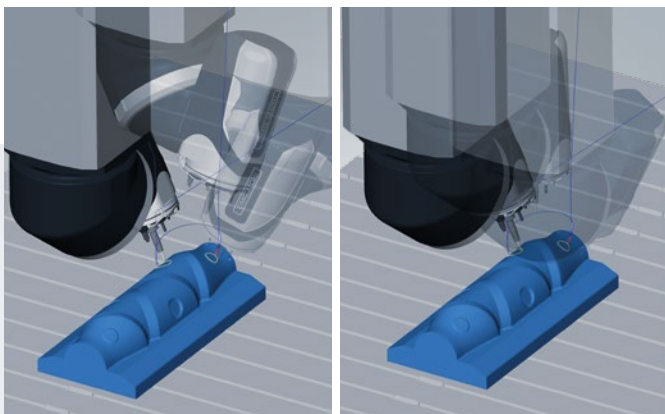

On the left image, a large machine head movement is visible; on the right image, the optimized movement

Solution selection: Closest C-axis angle

When selecting the preferred direction under the “NC Solutions” tab in the job setup, you can now select the option “Closest C-angle”. This allows you to control the positioning solution specifically via a preferred C-axis position. Plus and minus solutions are selected so that the C-axis remains as close as possible to the defined angle – even when 5-axis machining. With a *hyperMILL*® VIRTUAL Machining Optimizer license, possible collisions or axis limit violations can be prevented during NC generation.

Benefit: Avoiding large C-axis rotations in non-pole situations, increased machining accuracy, and reduced programming effort.

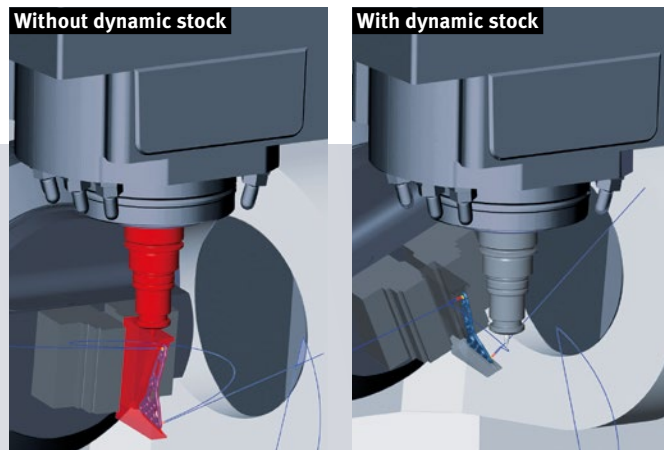

Linking with dynamic stock

You can now use the “Use dynamic stock” option for smooth linking movements generated by the *hyperMILL*® Optimizer. An updated stock is automatically generated for all machining jobs in the job list and taken into account when calculating the linking movements. This allows you to create linking movements that are optimized for the actual stock conditions.

Benefit: Optimized linking movements.

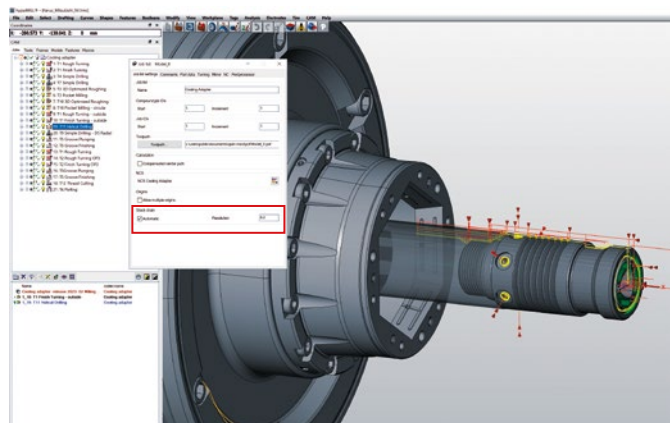

Name	Joblist name
✓ Cooling adapter - release 2023- 02 Stock	Cooling adapter
✓ Cooling adapter - release 2023- 02 Turn Stock	Cooling adapter
✓ 1_1 T1 Rough Turning	Cooling adapter
✓ 1_2 T1 Finish Turning	Cooling adapter
✓ 1_3 T4 Simple Drilling	Cooling adapter
✓ 1_4 T7 Simple Drilling	Cooling adapter
✓ 1_5 T3 3D Optimized Roughing	Cooling adapter
✓ 1_6 T3 Pocket Milling	Cooling adapter
✓ 1_7 T10 3D Optimized Roughing	Cooling adapter
✓ 1_8 T10 Pocket Milling - circular	Cooling adapter
✓ 1_9 T1 Rough Turning - outside	Cooling adapter
✓ 1_10 T1 Finish Turning - outside	Cooling adapter
✓ 1_10 T11 Helical Drilling	Cooling adapter
✓ 1_20 T9 Simple Drilling - D5 Radial	Cooling adapter
✓ 1_11 T5 Groove Plunging	Cooling adapter
✓ 1_12 T5 Groove Finishing	Cooling adapter
✓ 1_13 T11 Rough Turning	Cooling adapter
✓ 1_14 T2 Rough Turning OPS	Cooling adapter
✓ 1_15 T2 Finish Turning OPS	Cooling adapter
✓ 1_16 T5 Groove Plunging	Cooling adapter
✓ 1_17 T5 Groove Finishing	Cooling adapter
✓ 1_21 T6 Parting	Cooling adapter

HIGHLIGHT

Automatic stock chain

The new version provides you with a completely new stock handling system in *hyperMILL*®. Fully automatic, powerful, intelligent, and applicable across all all types of machining, from drilling, turning and milling to additive machining. Activate the option “Automatically create stock chain” in the job list under the definition of a resolution, and *hyperMILL*® automatically creates all stock models in the correct order. If a machining job is deleted or reordered, *hyperMILL*® adjusts the stock chain accordingly. Likewise, a machining job can be removed from the stock chain if necessary. Otherwise, no user interaction is required, and from creation to handover to the simulation or the virtual machine, *hyperMILL*® handles all stock models.

Benefit: Simplified and user-friendly handling and creation of stock models.

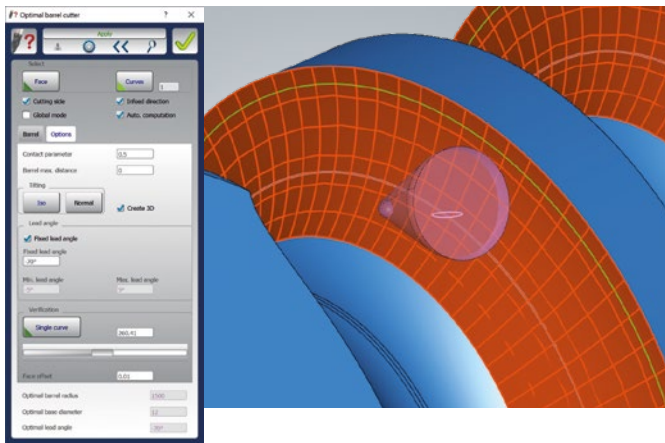
**HIGHLIGHT****Optimal barrel cutter**

Thanks to the new function “Optimal barrel cutter” under the “CAM” tab, you can analyze the use of a barrel cutter for your machining areas. The analysis uses one of the three types of barrel cutters: conical, tangential, or general. For each barrel type, a range for the base diameter and barrel radius can be defined, so that the optimal cutter geometry is displayed during the analysis. Additionally, you can optimize the usable barrel radius through the analysis of the lead angle or determine the optimal barrel radius using the contact parameter control and the maximum barrel radius distance parameter. This function helps you select a suitable barrel cutter and ensures its optimized use.

Benefit: Simple and fast analysis for the optimal use of barrel cutters.

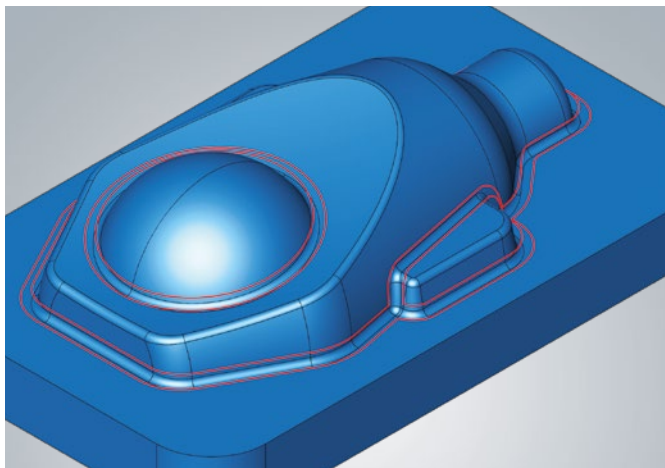
**Rest material boundary**

For more flexibility in processing rest material, you can now create limits for rest material areas and use them in any strategy. Based on the definition of a reference tool, the theoretical remaining material for the milling area is calculated and marked using boundary contours. The boundaries refer to the center point of the selected tool and provide flexible use with different approaches.

Benefit: Simple and fast creation of rest material boundaries.

**HIGHLIGHT****hyperMILL® AUTOMATION Center Controller**

The new *hyperMILL*® AUTOMATION Center Controller enables you to easily manage and structure self-developed scripts and script blocks. This gives you a better overview and access to your automation scripts. Create favorites and organize your scripts within them. Filtering for specific scripts is always possible. To help understand this function, a set of example data that you can customize and expand is provided with the release of AUTOMATION Center Controller. In the controller, combined scripts or script blocks can be executed automatically. To do this, the sequence must be saved in a favorite.

Benefit: Improved organization and application of automation scripts.

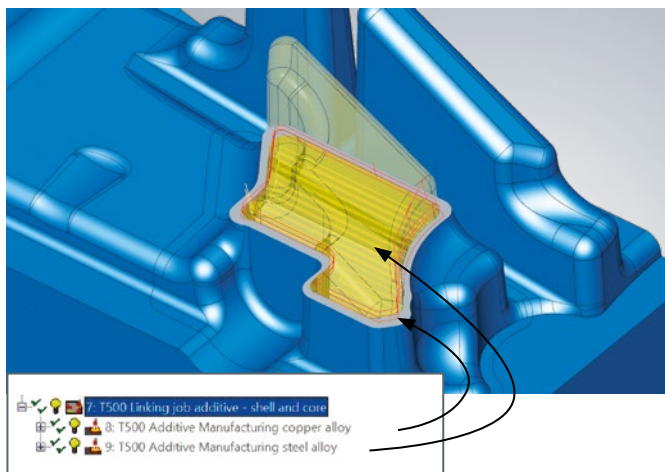

hyperMILL® ADDITIVE Manufacturing

The new “Linking Job” for additive manufacturing simplifies the programming of complex processes, enhancing user-friendliness and efficiency. Effortlessly link multiple additive jobs with different technology parameters and 5-axis strategies for an optimized workflow.

The “Additive Manufacturing” job now features an advanced 5-axis automatic tool orientation mode, enabling safe and efficient operations even in tight spaces. By analyzing the model and additive device, it accurately determines the optimal approach whether indexed or simultaneous.

Benefit: Simplified programming of additive processing jobs.

Safely generate, optimize, and simulate NC code

hyperMILL®
VIRTUAL Machining

hyperMILL® VIRTUAL Machining bridges the gap between CAM system and real machine-environment – for unparalleled process control and optimization. This is Industry 4.0!

Our VIRTUAL Machining technology ensures safe CNC machining from programming to the machine.

- Optimization of motion sequences in the NC program
- Simplified programming
- Digital twin of your machine
- NC code-based simulation
- Automatic solution selection
- Perfect machine connectivity due to bidirectional communication
- Bidirectional data exchange between CAM and machine



Find out here how you can benefit from our Optimizer technology



Automatically generated connection movements between 2D-, 3D- and 5-axis operations and various positions



At the push of a button, our optimizer transforms X/Y movements into movements with the rotary axis



Necessary rewind movements are automatically generated and inserted into the NC code

HEADQUARTERS

OPEN MIND Technologies AG
Argelsrieder Feld 5 • 82234 Wessling • Germany
Phone: +49 8153 933-500
E-mail: Info.Europe@openmind-tech.com
Support.Europe@openmind-tech.com

PORTUGAL

OPEN MIND Technologies Portugal, Unipessoal, Lda
Edifício Centro de Negócios MAPER • Fração N e O
Estr. Nacional 242, Km 9,2 • 2430-074 Marinha Grande
Phone: +351 244 023 359
E-mail: Info.Portugal@openmind-tech.com

SWEDEN

OPEN MIND Technologies Scandinavia AB
C/O ISO Tool AB
Enhörningsvägen 8 A • 281 43 Hässleholm
E-mail: Info.Scandinavia@openmind-tech.com

UK

OPEN MIND Technologies UK Ltd.
Unit 3 • Bicester Business Park
Telford Road • Bicester • Oxfordshire OX26 4LN
Phone: +44 1869 290003
E-mail: Info.UK@openmind-tech.com

USA

OPEN MIND Technologies USA, Inc.
1492 Highland Avenue, Unit 3 • Needham MA 02492
Phone: +1 888 516-1232
E-mail: Info.Americas@openmind-tech.com

BRAZIL

OPEN MIND Tecnologia Brasil LTDA
Av. Andromeda, 885 SL2021
06473-000 • Alphaville Empresarial
Barueri • São Paulo
Phone: +55 11 2424 8580
E-mail: Info.Brazil@openmind-tech.com

ASIA-PACIFIC

OPEN MIND Technologies Asia Pacific Pte. Ltd.
MOVA Building, 22 Jalan Kilang • #03-00
Singapore 159419
Phone: +65 6742 95-56
E-mail: Info.Asia@openmind-tech.com

CHINA

OPEN MIND Software Technologies China Co., Ltd.
Suite 1608 • Zhong Rong International Plaza
No. 1088 South Pudong Road
Shanghai 200120
Phone: +86 21 588765-72
E-mail: Info.China@openmind-tech.com

INDIA

OPEN MIND CAD/CAM Technologies India Pvt. Ltd.
No. 610 and 611 • 6th Floor • 'B' Wing
No. 6, Mittal Tower, M.G. Road
Bangalore 560001 • Karnataka
Phone: +91 80 2676 6999
E-mail: Info.India@openmind-tech.com

JAPAN

OPEN MIND Technologies Japan K.K.
Albergo Musashino B101, 3-2-1 Nishikubo
Musashino-shi • Tokyo 180-0013
Phone: +81 50 5370-1018
E-mail: Info.Japan@openmind-tech.com

TAIWAN

OPEN MIND Technologies Taiwan Inc.
Rm. F, 4F., No.1, Yuandong Rd., Banqiao Dist.
New Taipei City 22063
Phone: +886 2 2957-6898
E-mail: Info.Taiwan@openmind-tech.com

OPEN MIND Technologies AG is represented worldwide with own subsidiaries and through competent partners and is a member of the Mensch und Maschine technology group, www.mum.de



 **OPEN MIND**
THE CAM FORCE

We push machining to the limit

www.openmind-tech.com